

# **US MOWER**

**OPERATOR'S MANUAL**

## **EX40**

## **EX40HD**

**FLAIL MOWER**



11949 WESTAR LN  
BURLINGTON, WA 98233  
360.757.7555

[WWW.USMOWER.COM](http://WWW.USMOWER.COM)

## **Creating Mowing Solutions    Manufactured in the USA**



US MOWER ROTARY AND FLAIL MOWERS FOR EXCAVATOR AND SKID STEERS ARE USED BY COMMERCIAL MOWERS FOR INDUSTRIAL MOWING APPLICATIONS INCLUDING LAND CLEARING, PIPELINE MAINTENANCE, DITCH MAINTENANCE AND GENERAL HERBICIDE FREE VEGETATION MANAGEMENT. WE OFFER ROTARY MOWERS AND FLAIL MOWERS FOR BOTH SKID STEERS AND EXCAVATORS AS WELL AS COMPLETE TRACTOR INTEGRATED MOWERS FOR CASE, JOHN DEERE, NEW HOLLAND, CHALLENGER AND MCCORMICK. US MOWER EQUIPMENT IS MANUFACTURED TO HAVE A LONG, PRODUCTIVE SERVICE LIFE. MANY CONTRACT MOWERS HAVE REPORTED 5,000 OR MORE HOURS OF WORKING TIME ON THEIR MOWING EQUIPMENT. THE VERY FIRST FLAIL MOWER BUILT IN 1999 IS STILL IN USE TODAY.

ALL US MOWER FLAIL MOWERS AND ROTARY MOWERS ARE DESIGNED AND MANUFACTURED IN BURLINGTON, WA. FROM IDEA TO FINISHED PROJECT, IT ALL HAPPENS RIGHT HERE IN OUR USA FACTORY. EACH DESIGN FEATURE, MATERIAL AND COMPONENT IS CAREFULLY SELECTED TO PROVIDE THE BEST PERFORMANCE AND VALUE TO OUR CUSTOMER. WE KNOW THAT A FLAIL OR ROTARY MOWER IS A BIG INVESTMENT TO OUR CUSTOMER, SO WE MAKE IT FROM HIGH STRENGTH STEEL, DOM TUBING, AND OTHER HIGH QUALITY MATERIALS AND COMPONENTS. WE ALSO SERVICE AND STOCK EACH COMPONENT TO BUILD THE MOWERS AND OUR CUSTOMERS CAN PURCHASE THEM DIRECT FROM US MOWER OR ONE OF OUR FANTASTIC DEALERS LOCATED THROUGHOUT THE USA AND CANADA. BECAUSE WE ARE A FABRICATING MANUFACTURER, WE CAN ALSO MAKE CUSTOM MOUNTS, A VARIETY OF OPTIONS AND SPECIAL REQUESTS.



**360.757.7555    www.usmower.com**

**FAILING TO FOLLOW SAFETY MESSAGES AND OPERATING INSTRUCTIONS CAN CAUSE SERIOUS BODILY INJURY OR EVEN DEATH TO THE OPERATOR OR OTHERS IN THE AREA. YOUR MOWER IS A POWERFUL INDUSTRIAL MACHINE WITH SUBSTANTIAL CAPACITY TO CAUSE PROPERTY DAMAGE, PERSONAL INJURY OR EVEN DEATH WHEN USED IMPROPERLY OR WITHOUT PROPER SAFETY EQUIPMENT.**

## **BEFORE YOU START!!**

READ THE SAFETY MESSAGES ON THE IMPLEMENT AND IN YOUR MANUAL. US MOWER HAS DESIGNED THIS IMPLEMENT TO BE USED WITH ALL ITS SAFETY EQUIPMENT PROPERLY ATTACHED TO MINIMIZE THE CHANCE OF INJURY IN THE EVENT OF AN ACCIDENT. THERE IS NO SUBSTITUTE FOR AN INFORMED, CAUTIOUS, SAFE-MINDED OPERATOR WHO RECOGNIZES POTENTIAL HAZARDS AND FOLLOWS GOOD SAFETY PRACTICES.

- STUDY OPERATOR'S MANUALS AND SAFETY DECALS FOR EXCAVATOR AND CUTTER THOROUGHLY TO PREVENT MISUSE, ABUSE AND ACCIDENTS.
- DO NOT ALLOW RIDERS ON EXCAVATOR OR IMPLEMENT. FALLING OFF MAY CAUSE SERIOUS INJURY OR DEATH BY BEING RUN OVER BY EXCAVATOR OR CUTTER. KEEP CHILDREN AWAY!
- OPERATE WITH ROPS AND FASTENED SEAT BELT TO PREVENT INJURY AND POSSIBLE CRUSHING DEATH FROM FALLING OFF OR EXCAVATOR OVERTURN.
- WEAR HARD HAT AND SAFETY GLASSES FOR PERSONAL PROTECTION.
- MAKE CERTAIN THAT SMV SIGN, WARNING LIGHTS AND REFLECTORS ARE CLEARLY VISABLE.
- BLOCK UP OR SUPPORT CUTTER SECURELY BEFORE PUTTING HANDS OR FEET UNDER OR WORKING UNDERNEATH LIFTED COMPONENTS TO PREVENT CRUSHING INJURY OR DEATH FROM SUDDEN, INADVERTENT DROPPING. MAKE CERTAIN AREA IS CLEAR BEFORE LOWERING.
- FOLLOW LOCAL TRAFFIC CODES. SLOW DOWN AT NIGHT, IN TURNS, AND ON HILLSIDES.
- BEFORE DISMOUNTING, SECURE IMPLEMENT IN TRANSPORT POSITION OR LOWER TO GROUND. DISENGAGE INTERLOCK, TURN OFF MACHINE. NEVER MOUNT OR DISMOUNT A MOVING VEHICLE TO PREVENT CRUSHING INJURY OR DEATH.

**THERE ARE OBVIOUS AND HIDDEN POTENTIAL HAZARDS INVOLVED IN THE OPERATION OF THIS MOWER. SERIOUS INJURY OR DEATH MAY OCCUR UNLESS CARE IS TAKEN TO INSURE THE SAFETY OF BOTH THE OPERATOR AND OTHER PERSONS IN THE AREA. THE FOLLOWING IS A LIST OF SOME SAFEGUARDS WHICH SHOULD BE FOLLOWED.**

**IN ADDITION TO THE DESIGN AND CONFIGURATION OF EQUIPMENT, HAZARD CONTROL AND ACCIDENT PREVENTION ARE DEPENDENT UPON AWARENESS, CONCERN AND PRUDENCE. SUITABLE TRAINING OF PERSONNEL INVOLVED IN THE OPERATION, TRANSPORT, MAINTENANCE AND STORAGE OF EQUIPMENT IS REQUIRED.**

- DRESS FOR THE JOB. CHOOSE CLOSE-FITTING CLOTHES AND LONG PANTS, HEARING PROTECTION, EYE PROTECTION, WORK BOOTS WITH TRACTION AND HEAVY GLOVES (WHEN HANDLING BLADES). DO NOT WEAR LOOSE-FITTING CLOTHES OR JEWELRY, WHICH CAN GET CAUGHT OR HUNG UP ON A MACHINE AND CAUSE INJURY.
- KNOW YOUR MACHINE. READ THE OPERATORS MANUAL TO FAMILIARIZE YOURSELF WITH YOUR MACHINES UNIQUE FEATURES. FOR EXAMPLE DEFLECTOR SHIELDS, ADJUSTMENTS, SKID SHOES, RETENTION SYSTEMS AND MAINTENANCE.
- READ WARNING LABELS AND CHECK SAFETY FEATURES. NEVER OPERATE YOUR MOWER IF YOUR SAFETY GUARDS AND DEVICES ARE NOT IN PLACE. REPLACE SAFETY GUARDS AND DEVICES IF DAMAGED OR NOT OPERATING PROPERLY.
- STOP MOWING IF PASSERSBY ARE WITHIN 50 YARD RADIUS FROM MOWER HEAD.
- NEVER ALLOW CHILDREN TO OPERATE, RIDE ON, OR COME CLOSE TO MOWER OR EQUIPMENT. NEVER LIFT A PERSON OR ALLOW ANYONE TO STAND ON A MOWER HEAD. KEEP BYSTANDERS AND PETS CLEAR AND OFF OF EQUIPMENT.
- EXTREME CARE SHOULD BE TAKEN WHEN OPERATING NEAR LOOSE OBJECTS SUCH AS GRAVEL, ROCKS OR GENERAL DEBRIS. THESE OBJECTS SHOULD BE REMOVED OR AVOIDED TO PREVENT INJURY FROM THROWN OBJECTS. WHERE GRASS AND WEEDS ARE HIGH ENOUGH TO HIDE DEBRIS THAT COULD BE STRUCK BY THE BLADES, THE AREA SHOULD BE INSPECTED AND LARGE DEBRIS REMOVED. MOW CLEARED AREA AT AN INTERMEDIATE HEIGHT, INSPECT CLOSELY FOR REMAINING DEBRIS AND REMOVE. MOW AGAIN AT DESIRED FINAL HEIGHT.
- KEEP THE MOWER HEAD AT LEAST 10 FEET FROM ELECTRIC LINES AND PIPE LINES TO PREVENT ACCIDENTAL CONTACT AND POSSIBLE SERIOUS INJURY OR EVEN DEATH.
- PRESSURIZED HYDRAULIC FLUID CAN PENETRATE THE SKIN CAUSING SERIOUS INJURY. DO NOT USE YOUR HAND TO CHECK FOR LEAKS ON A PRESSURIZED SYSTEM. USE A PIECE OF CARDBOARD OR PAPER TO SEARCH FOR LEAKS. STOP THE ENGINE AND RELIEVE PRESSURE BEFORE CONNECTING OR DISCONNECTING LINES. TIGHTEN ALL CONNECTIONS BEFORE STARTING THE ENGINE OR PRESSURIZING LINES. IF FLUID IS INJECTED INTO THE SKIN, OBTAIN MEDICAL ATTENTION IMMEDIATELY.
- CHECK ATTACHMENT POINTS. CHECK YOUR MOWER'S CONNECTION TO THE POWER UNIT. ALL PINS, BUSHINGS AND LINKAGE SHOULD BE CHECKED TO INSURE THEY ARE FREE TO TRAVEL THE FULL DISTANCE WITHOUT INTERFERENCE. REPAIR IF NECESSARY.
- CONDUCT DAILY INSPECTIONS. VERIFY THAT ALL SHIELDS AND GUARDS ARE IN PROPER WORKING ORDER. CHECK BLADE ATTACHMENT BOLTS TO INSURE ALL BLADES ARE PRESENT AND IN GOOD CONDITION. CHECK BLADES FOR CRACKS AROUND BOLT HOLE. CHECK THAT HYDRAULIC HOSE CONNECTIONS ARE COMPLETELY ENGAGED.



**STOP! AND ALLOW ALL VEHICLES TO PASS THROUGH OPERATING "SAFETY ZONE" BEFORE CONTINUING CUTTING. OPERATOR AWARENESS IS KEY TO SAFE OPERATION. NEVER OPERATE OR CONTINUE TO OPERATE THIS MACHINE WHEN THERE IS A PERSON OR VEHICLE WITHIN A 50 YARD RADIUS OF THE CUTTING OPERATION. IF A PERSON COMES INSIDE YOUR OPERATING "SAFETY ZONE" (50 YARD RADIUS) SHUT THE MACHINE DOWN.**

**KNOW YOUR OPERATING SAFETY ZONE!!**

**BEFORE STARTING THE OPERATOR SHOULD READ AND UNDERSTAND THE OWNER/OPERATION MANUAL FOR THE PARENT IMPLEMENT TO DETERMINE THE PROPER PROCEDURE FOR TURNING ON THE AUXILIARY HYDRAULICS TO RUN THE MOWER.**

### **MOUNTING THE MOWER**

AFTER REMOVING THE BUCKET FROM THE STICK BY DISCONNECTING THE QUICK ATTACH MECHANISM INSTALL THE MOWER IN IT'S PLACE. THE MOWER WITH ITS' MOUNT SHOULD READILY ATTACH IN PLACE OF THE BUCKET. CONFIRM THAT THE LOCKING MECHANISM IS PROPERLY ENGAGED. INSTALL THE CASE DRAIN LINE AND THEN, ATTACH THE SUPPLIED HOSES WITH QUICK COUPLERS TO THE AUXILIARY CIRCUIT LINES ON THE EXCAVATOR. MAKE SURE THAT THE QUICK CONNECT COUPLERS ARE COMPLETELY ENGAGED.

### **CASE DRAIN LINE, WHAT AND WHY IS IT NEEDED?**

THE CASE DRAIN PROTECTS THE MOTOR SHAFT SEAL FROM EXCESSIVE PRESSURE. MOTOR SHAFT SEALS ARE USUALLY RATED TO 100 PSI FOR BRIEF PERIODS OR LESS THAN ABOUT 50 PSI CONTINUOUSLY. HIGH PRESSURE OIL FROM THE GEAR SECTION TRAVELS BETWEEN THE SHAFT AND ITS SLEEVE BEARING TO AN AREA BEHIND THE SHAFT SEAL. THROUGH THE RETURN LINE BY WAY OF AN INTERNAL CHECK VALVE OR THROUGH AN EXTERNAL CASE DRAIN. IN MOST COMPACT EQUIPMENT RETURN LINE PRESSURE IS HIGH ENOUGH TO CAUSE EITHER ABRUPT SEAL BLOW-OUT (150+ PSI) OR EARLY FAILURE OF THE MOTOR SHAFT. HIGHER PRESSURE SEALS ARE AVAILABLE, BUT ARE NOT ALWAYS RELIABLE AND CAUSE OTHER PROBLEMS AS WELL.

THE BEST SOLUTION IS A DEDICATED CASE DRAIN. YOUR MACHINE MAY HAVE AN INTERNAL OR EXTERNAL CASE DRAIN SYSTEM THAT CAN ACCOMMODATE THE SMALL VOLUME OF GEAR MOTOR CASE FLOW. CONTACT YOUR VEHICLE DEALER OR MANUFACTURER FOR TECHNICAL DETAILS.

**MOTOR SHAFT SEALS ARE NOT COVERED UNDER WARRANTY IF CASE DRAIN IS NOT PROPERLY INSTALLED OR FAILS. MAKE SURE CASE DRAIN LINE COUPLERS ARE PROPERLY CONNECTED.**

### **ATTACHING MOWER TO EXCAVATOR**

SECURELY ATTACH THE FLAIL MOWER IN THE SAME MANNER YOU WOULD ATTACH A BUCKET OR OTHER EXCAVATOR ATTACHMENT. CONFIRM THAT THE LOCKING MECHANISM IS PROPERLY ENGAGED.

CAREFULLY CLEAN THE HYDRAULIC QUICK COUPLERS BEFORE MAKING CONNECTIONS. DIRT QUICKLY DAMAGES THE HYDRAULIC SYSTEM. ALWAYS COVER OR CONNECT COUPLERS TOGETHER WHEN NOT IN USE.

CONNECT SUPPLY, RETURN AND CASE DRAIN LINES. CONFIRM THAT THE HYDRAULIC QUICK COUPLERS ARE FULLY ENGAGED AND LOCKED BY TURNING THE COLLARS. CHECK WITH YOUR POWER UNITS MANUALS ON HOW BEST TO RELEASE THE PRESSURE IN THE AUXILIARY LINES FOR EASY COUPLING TO THE CONNECTORS.

ACTIVATE THE AUXILIARY HYDRAULIC CIRCUIT WITH THE CUTTER HEAD RAISED OFF THE GROUND. THE CUTTER SHAFT SHOULD TURN FREELY AND SMOOTHLY.

## MOWING WITH THE EXCAVATOR FLAIL

TECHNIQUES VARY WITH THE OPERATOR AND THE MOWING TASK. HOWEVER, THE FACTORS BELOW SHOULD BE KEPT IN MIND.

- THE MOWER IS FRAGILE COMPARED TO AN EXCAVATOR BUCKET. THE BUCKET IS DESIGNED TO WITH STAND VERY HIGH DIGGING FORCE. THE MOWER WILL CRUMPLE WITH ANY SUBSTANTIAL FRACTION OF THAT. KEEP IN MIND THAT EXCAVATOR MOWING REQUIRES A LIGHT HAND. DO NOT PUSH ON THE MOWER HEAD TO MOVE THE EXCAVATOR OR TO PUSH OBJECTS.
- IT IS PARTICULARLY IMPORTANT TO AVOID PUSHING WITH THE FLAIL SHAFT. KEEP THE FLAIL SHAFT AND BLADE TOWERS CLEAR OF SOLID OBJECTS. LET THE BLADES DO THE CUTTING. BENDING THE FLAIL SHAFT WILL RESULT IN VIBRATION THAT REQUIRES REMANUFACTURING THE SHAFT TO FIX. DO NOT CONTINUE TO MOW WITH A SEVERELY BENT OR UNBALANCED SHAFT.
- GOOD PERFORMANCE DEPENDS ON THE FREE SWINGING OF THE BLADES. THE TWO POUND BLADES CAN SEVER 4 INCH DIAMETER SOFT WOOD WITH ONE HIT OF ONE BLADE. FORCING THE FLAIL INTO VEGETATION, SUCH THAT THE BLADES ARE HELD AGAINST THE FLAIL SHAFT, SLOWS MOWING. KEEP THE BLADES SWINGING.
- THE FLAIL MOWER IS DESIGNED TO CUT ALL TYPES OF GRASSES, BRUSH AND SMALL TREES. THE GROUND CONDITIONS AND THE TYPE OF BRUSH BEING CUT WILL DETERMINE THE BEST CUTTING PROCEDURE AND GROUND SPEED.
- SHARP BLADES MAKE A SUBSTANTIAL DIFFERENCE IN CUTTER EFFICIENCY. THIS IS MOST NOTICEABLE IN HEAVY CONDITIONS WHEN THE MOWER IS OPERATING AT CAPACITY. RUNNING THE BLADES INTO ROCKS OR OTHER HARD OBJECTS WILL BLUNT BLADES AND WILL REDUCE MOWING CAPACITY.
- FLAIL MOWERS CAN BE EQUIPPED WITH CUT HEIGHT ADJUSTING ROLLER FOR BRUSH CUTTING AT GROUND LEVEL. FOR BRUSH CUTTING AT HIGHER LEVELS, INCLUDING CANOPY MOWING, THE ROLLER IS BEST LEFT OFF.

**CUTTER SHAFT SHOULD BE RUN AT 1800 TO 2000 RPM.**

### CLEARING BRUSH IN AN OPEN AREA

- POSITION THE EXCAVATOR AT A STARTING POINT. SET THE HEIGHT OF MOWER HEAD SO THE BRUSH IS LESS THAN ABOUT 2 FEET ABOVE THE TOP OF THE MOWER. SWING THE MOWER THROUGH THE BRUSH MATCHING THE SWING SPEED TO THE PERFORMANCE OF THE MOWER. OVER FEEDING THE MOWER WILL DRAG DOWN CUTTER SHAFT SPEED REDUCING MOWER EFFICIENCY. LOWER THE HEAD AND SWING AGAIN. REPEAT UNTIL DESIRED CUT HEIGHT IS REACHED.

### CANOPY MOWING & TREES

- CANOPY MOWING REQUIRES ROTATING THE HEAD SO THAT THE FLAIL IS UPSIDE DOWN AND POSITIONED UPWARD, THE LEVEL OF THE CANOPY TO BE CUT. TURNING THE CAB FROM SIDE TO SIDE WHILE MOVING THE EXCAVATOR FORWARD, ONE CAN READILY MOW THE UNDERSIDE OF A TREE CANOPY.
- TREE MOWING IS GENERALLY BEST DONE BY FIRST RUNNING THE FLAIL HEAD UP AND DOWN THE TRUNK REMOVING THE BRANCHES. IF THE TREE IS NOT TOO LARGE, POSITIONING THE HEAD AT THE TOP OF WHAT REMAINS OF THE TRUNK WHILE WORKING THE HEAD UP AND DOWN CAN REDUCE THE TRUNK TO LITTLE MORE THAN A STUMP. BEAR IN MIND, HOWEVER, THAT THE FLAIL IS NOT A CHIPPER OR STUMP GRINDER. ITS ABILITY TO DO THIS KIND OF CUTTING IS LIMITED BY THE HARDNESS OF THE MATERIAL.

**FREQUENT AND ROUTINE MAINTENANCE PROCEDURES SHOULD BE FOLLOWED TO ENSURE THE SAFE AND EFFICIENT OPERATION OF THE MOWER. THE FOLLOWING PROCEDURES SHOULD BE PERFORMED EVERY 8 WORKING HOURS. UNDER SEVERE CONDITIONS THIS SCHEDULE SHOULD BE ACCELERATED.**

- CHECK FREE END BEARING AND BEARING HOUSING FOR EXCESSIVE HEAT: INDICATING LOSS OF LUBRICATION OR POSSIBLE BEARING DAMAGE.
- CHECK BLADES, BLADE BOLTS, NUTS AND TOWERS FOR EXCESSIVE WEAR, CHIPPING OR CRACKING.
- GREASE BEARINGS: FREE END ~4 PUMPS EVERY 4 HOURS — DRIVE END UNTIL GREASE COMES OUT THE BREATHER
- CHECK HYDRAULIC LINES FOR DAMAGE AND LEAKS.
- CLEAN DEBRIS, LEAVES, GRASS AND STICKS FROM INSIDE SHROUD AND OR ROLLERS.
- CHECK BOLTS AND NUTS ON ALL MOUNTINGS AND OPTIONAL EQUIPMENT.
- CHECK DEPENDING ON YOUR OPTIONS: GATES, SHIELDS, SHROUD AND ROLLERS ETC. REPAIR IF DAMAGED OR REPLACE IF NECESSARY.

### **LUBRICATION**

THE DRIVE END BEARING HOUSING HAS A GREASE ZERK AND A GREASE VENT PLUMBED TO THE SURFACE OF THE MOWER ENCLOSURE. THE AMOUNT NEEDED VARIES WITH AMBIENT TEMPERATURE AND MOWING LOAD. GENERALLY GREASING TWICE A DAY IS SUFFICIENT FOR HEAVY OPERATION. A GOOD QUALITY NLGI#2 LITHIUM GREASE IS USUALLY SATISFACTORY. IF THE BEARING HOUSING IS PUMPED FULL OF GREASE WHEN COLD, AT FIRST RUN UP AFTER A COLD FILL, A SUBSTANTIAL QUANTITY OF GREASE WILL ISSUE FROM THE VENT AS THE GREASE HEATS. THIS IS NORMAL. TO REDUCE THIS, GREASE WHEN EQUIPMENT IS AT OPERATING TEMPERATURE.

### **INSPECT BEFORE MOWING**

INSPECT CUTTER DRUM AND KNIVES. INSPECT THE BLADES FOR WEAR, DAMAGE & CRACKS. INSPECT TOWERS FOR CRACKS. INSPECT BLADE BOLTS FOR WEAR AND TIGHTNESS. REPLACE OR REPAIR ANY PROBLEM ITEMS IMMEDIATELY. INJURY CAN BE CAUSED IF A BLADE OR TOWER IS THROWN FROM CUTTER SHAFT WHILE MOWING.

### **REPLACING BLADES AND BLADE BOLTS**

YOUR MOWER WILL BE MORE EFFICIENT IF RUNNING WITH SHARP BLADES. BLADES MAY BE TURNED AROUND IF ONE SIDE IS WORN. BLADES SHOULD BE REPLACED IN SETS TO MAINTAIN CUTTER SHAFT BALANCE. BLADE BOLTS, WASHERS AND BOLT NUTS SHOULD BE EXAMINED AND REPLACED IF WORN. BEAR IN MIND THAT PARTS SUBJECT TO INTENSE POUNDING WILL IN TIME DEVELOP FATIGUE CRACKS.

INSTALL THE BLADE ASSEMBLY AS SHOWN IN THE SHAFT DIAGRAM. NOTE THAT IF TOP LOCK NUTS ARE USED THEY SHOULD BE THREADED ONTO THE BOLT SUCH THAT THE NUT RUNS OUT OF BOLT THREADS. IT IS THE RESULTING THREAD JAMMING EFFECT ON THE NUT THAT HOLDS IT IN PLACE AGAINST SHOCK AND VIBRATION. THIS TYPE OF NUT MUST BE DRIVEN TO REFUSAL WITH A 3/4" HIGH POWER IMPACT GUN.

## REPLACING BEARINGS—FREE END

### REMOVAL

1. LOOSEN THE SET SCREW THAT HOLDS THE COLLAR OF THE BEARING TO THE SHAFT.
2. UNBOLT THE (4) BOLTS THAT HOLD THE BEARING IN PLACE.
3. CLEAN DIRT AND RUST FROM SURFACE. SMOOTH OFF RAISED AREAS.
4. SLIDE THE BEARING OFF THE SHAFT. BECAUSE OF RUST OR NICKS ON THE SHAFT, A PULLER MAY BE NEEDED.

### INSTALLATION

1. CLEAN THE SHAFT AND BEARING BORE.
2. APPLY ANTI-SEEZE.
3. SLIDE BEARING IN PLACE.
4. INSTALL (4 ) BOLTS AND TORQUE TO 100 FT/LBS.
5. TIGHTEN COLLAR SET SCREWS.

## REPLACING BEARINGS—DRIVE END

1. REMOVE THE HOSES AND THE FOUR BOLTS HOLDING THE HYDRAULIC MOTOR TO THE END OF THE BEARING HOUSING AND REMOVE THE MOTOR.
2. LOOSEN THE 3 SET SCREWS ON THE NUT AND REMOVE THE NUT.
3. BLOCK UP THE CUTTER SHAFT.
4. REMOVE THE CLAMP RING THAT COMPRESSES THE OUTER EDGE OF THE RUBBER DISC.
5. YOU SHOULD NOW BE ABLE TO SLIDE THE BEARING HOUSING OFF THE SHAFT.
6. WHEN REASSEMBLING THE HOUSING, NOTE THE TWO BALL BEARINGS MUST BE INSTALLED SO THAT THEIR THRUST DIRECTION IS BACK TO BACK.
7. THIS IS ALSO A GOOD TIME TO EXAMINE THE RUBBER DISC AND SHAFT SEAL. INSPECT FOR TEARS, WEAR OR SEPARATION. REPLACE IF DAMAGED.





## INSTALLING THE COMPACT DRIVE NUT

DO NOT USE ANTI-SIZE ON THE NUT OR DRIVE STUB.

CAUTION: DO NOT TIGHTEN SET SCREWS BEFORE INSTALLING NUT.

1. THOROUGHLY CLEAN AND DEGREASE THE THREADS ON BOTH THE NUT AND THE DRIVE STUB.
2. APPLY BLUE LOCTITE TO SET SCREW AND STUB THREADS.
3. SCREW THE NUT ONTO THE DRIVE STUB AND TIGHTEN TO ABOUT 40 FT/LBS
4. TURN THE SHAFT 2-3 FULL ROTATIONS.
5. LOOSEN NUT SLIGHTLY AND TORQUE TO 40 FT/LBS
6. TAP THE NUT WITH A SMALL BALL PEEN HAMMER.
7. TORQUE AGAIN TO 20 FT/LBS.
8. TORQUE SET SCREWS TO 160 IN/LBS.

**BOLT TORQUE CHART**

SIZE	 SAE GRADE 2		 SAE GRADE 5		 SAE GRADE 8		 L9	
	ASSEMBLY TORQUE DRY	LUBRICATED	ASSEMBLY TORQUE DRY	LUBRICATED	ASSEMBLY TORQUE DRY	LUBRICATED	ASSEMBLY TORQUE DRY	LUBRICATED
1/4-20	66*	49*	8	75*	12	9	11	13
1/4-28	76*	56*	10	86*	14	10	13	13
5/16-18	11	8	17	13	20	18	21	21
5/16-24	12	9	19	14	25	20	23	23
3/8-16	20	15	30	23	45	30	33	33
3/8-24	23	17	35	25	50	35	38	38
7/16-14	30	24	50	35	70	55	60	60
7/16-20	35	25	55	40	80	60	65	65
1/2-13	50	35	75	55	110	80	95	95
1/2-20	55	40	90	65	120	90	105	105
9/16-12	65	50	110	80	150	110	140	140
9/16-18	75	55	120	90	170	130	150	150
5/8-11	90	70	150	110	220	170	185	185
5/8-18	100	80	180	130	240	180	205	205
3/4-10	160	120	260	200	380	280	290	290
3/4-16	180	140	300	220	420	320	355	355
7/8-9	190	140	400	300	600	460	505	505
7/8-14	210	155	440	320	660	500	585	585
1-8	220	160	560	440	900	680	775	775
1-14	240	170	640	480	1000	740	900	900
1 1/8-7	300	220	800	600	1280	960	1150	1150
1 1/8-12	340	260	880	660	1440	1080	1325	1325
1 1/4-7	420	320	1120	840	1820	1360	1600	1600
1 1/4-12	460	360	1240	920	2000	1500	1750	1750
1 3/8-6	560	420	1460	1100	2380	1780	—	—
1 3/8-12	640	460	1680	1260	2720	2040	—	—
1 1/2-6	740	560	1940	1460	3160	2360	3250	3250
1 1/2-12	840	620	2200	1640	3560	2660	3650	3650

ITEMS WITH \* = INCH POUNDS  
ALL OTHERS = FOOT POUNDS

"LUBRICATED"  
INCLUDES LUBRICANTS, LUBRIZING, PLATING, AND HARDENED WASHERS



## PARTS LIST-EX40 FLAIL MOWER

ITEM NO.	PART NUMBER	DESCRIPTION	QTY.
1	2562404	CD 40 Weldment	1
2	2564254	EX 40 Roller	1
3	2560205	1-7/16" Roller Bearing	2
4	2601731	Roller Arm	2
5	2561108	HCS 1/2 - 13 X 1.75	4
6	2557338	1/2"-13 Hex Nut	20
7	2560387	1/2-13X1-3/4 GR8 HCS	4
8	2557626	1/2" Flat Washer	36
9	2556428	3/8"-16 x 1 1/4 Grade 8 Bolt	16
10	2561301	3/8 Flat Washer Yellow Zinc	32
11	2562572	3/8"-16 Top lock Nut	16
12	2556827	1/2"-13 x 1.5" Grade 8 Bolt	8
13	2561108	1/2"-13 x 1 3/4 Grade 8 Bolt	16
14	2601719-1	Clamp Strip	2
15	2601701	CD50 Upper Cover	1
16	2601702	CD 50 Lower Cover	1
17	2562403	CD40 Cutter Shaft	1
18	2562404-6	CD40 Gate	2
19	DD40 Free End Bearing assy	Free End Bearing assy	1
20	2561436	Free End Bearing	1
21	2601500	Compact Drive SAE C	1
22	2559531	5/16 Flat Washer	24
23	2556618	5/16"-18 Lock nut	12
24	2558879	5/16"-18 x 1" Grade 8 Bolt	12

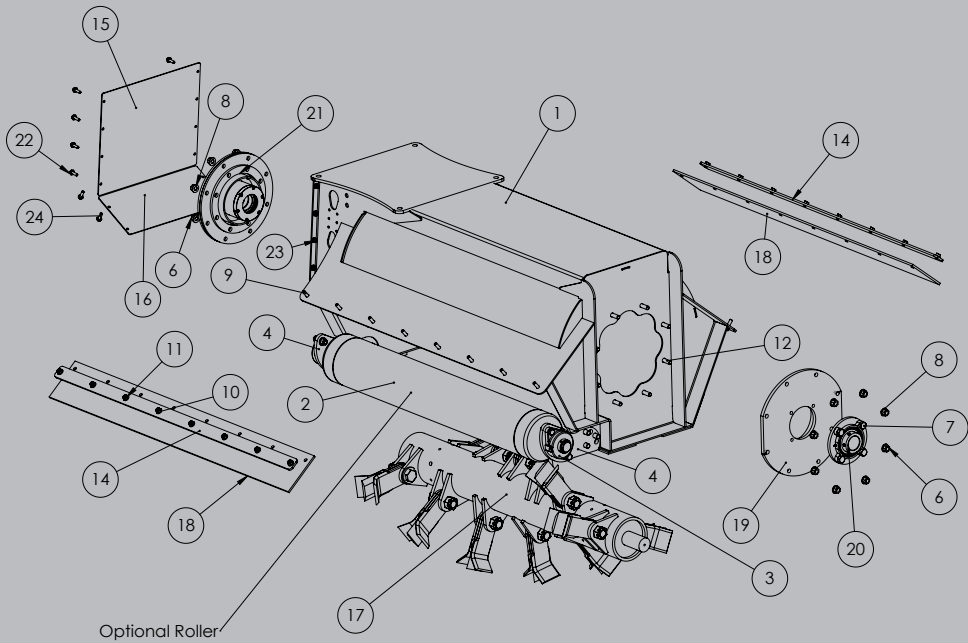

**ROLLER ASSEMBLY-OPTIONAL**  
**THUMB SADDLE-OPTIONAL**  
**(NOT SHOWN)**

## PARTS LIST-EX40HD FLAIL MOWER

ITEM NO.	PART NUMBER	DESCRIPTION	step 1/QTY.
1	2562485	CD40HD Lower Cover	1
2	2562484	CD40HD Upper Cover	1
3	2562932	CD40 HD Free End Bearing Plate assy	1
4	2562487	CD40HD Cutter Shaft Assy	1
5	2562486 Rev A	CD40HD Weldment (2013)	1
6	CD40HD Roller	CD40HD Roller	1
7	2562482	CD40HD Gate	2
8	2562483	CD40HD Gate Clamp	2
9	2601500-S	Compact Drive SAE C	1
10	2556827	1/2"-13 x 1.5" Grade 8 Bolt	8
11	2557338	1/2"-13 Hex Nut	16
12	2557626	1/2" Flat Washer	36
13	2561108	1/2"-13 x 1 3/4 Grade 8 Bolt	12
14	2559336	1/2"-13 x 2" Grade 8 Bolt	8
15	2561301	3/8 Flat Washer Yellow Zinc	56
16	2562572	3/8"-16 Top lock Nut	28
17	2559028	3/8-16 x 1 1/2 G8	16
18	2556428	3/8"-16 x 1 1/4 Grade 8 Bolt	12
19	2557339	5/8"-11 Top Lock Nut	4
20	2600375	5/8" Washer	6
21	2556605	5/8"-11 x 2 Grade 8 Bolt	4
22	2601730 L	Roller Arm Assy	1
23	2601730 R	Roller Arm Assy	1
24	2561436	Free End Bearing	1

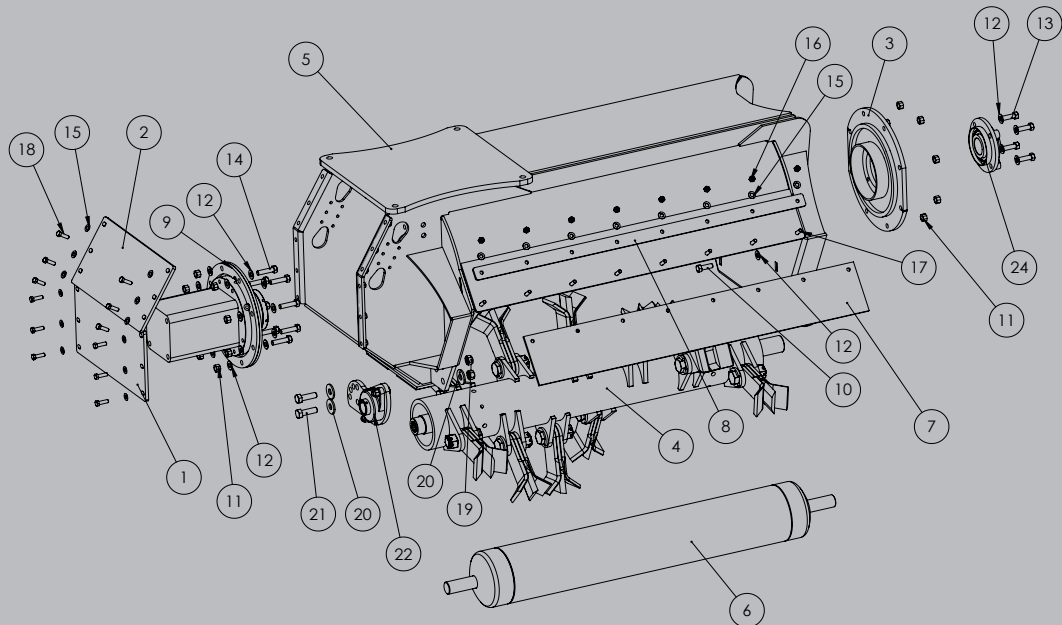

## DRIVE END ASSEMBLY

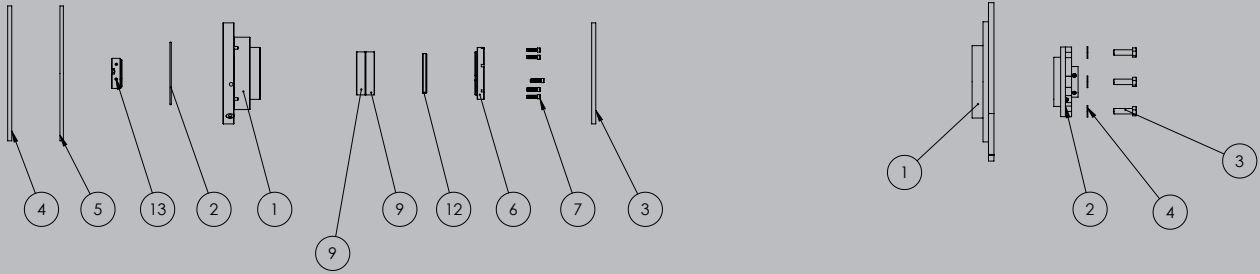

ITEM NO.	PART NUMBER	DESCRIPTION	QTY.
1	2601501-solid	CD saeC Base Plate-solid	1
2	2601507	o ring	1
3	2601509	Clamp Ring Inner	1
4	2601508	outer Clamp Ring	1
5	2601510	Drive Iso	1
6	2601503	CD saeC Cap	1
7	2562274	1/4 - 20 x 1.0 SHCS	6
8	2601505	Drive End Bearing	1
9	2601505	Drive End Bearing	1

ITEM NO.	PART NUMBER	DESCRIPTION	QTY.
1	2562932	CD40 HD Free End Bearing Plate assy	1
2	2561436	Free End Bearing	1
3	2561108	1/2"-13 x 1 3/4 Grade 8 Bolt	4
4	2557626	1/2" Flat Washer	4

ITEM NO.	PART NUMBER	DESCRIPTION	QTY.
12	2601504	Seal - SKF CR_25076	1
13	2601506	Nut - SKF KMTA_10	1

## CUTTER SHAFT ASSEMBLY

**EX40 #2562403**

**EX40HD #2562487**

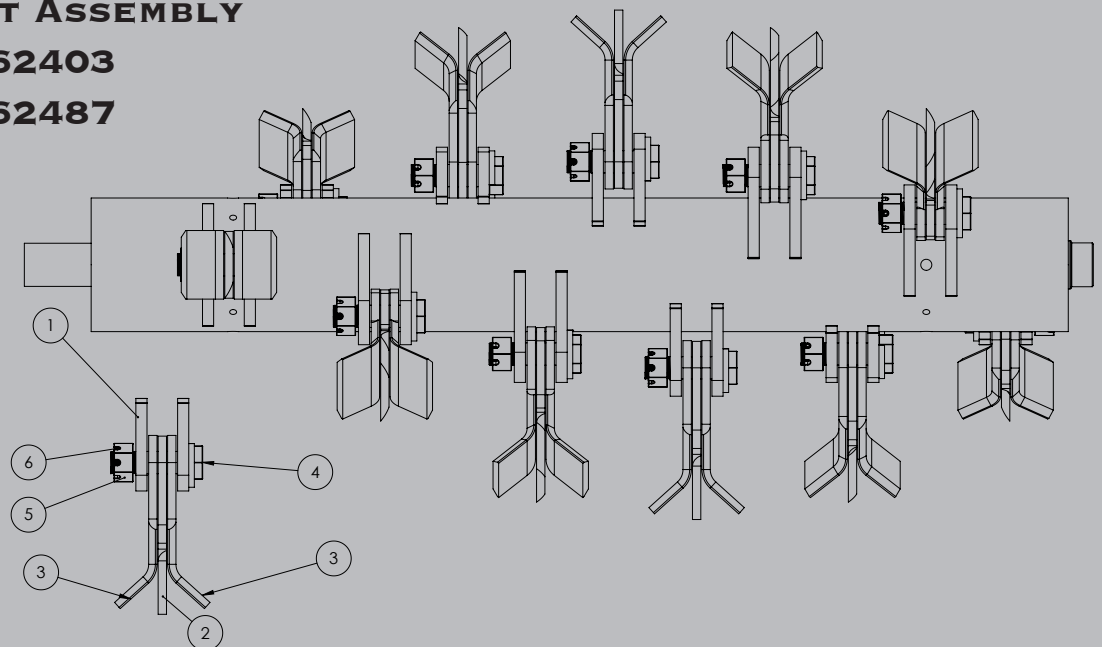

ITEM NO.	PART NUMBER	DESCRIPTION	QTY.
1	2559277	1/2" Cutter Shaft Tower	2
2	2560622	De-Thatch Blade	1
3	2558468	2lb. Forged Blade	2
4	2558544	1" Blade Bolt - Std	1
5	2558349	1" Slotted Nut	1
6	2560759	1/4" X 1-1/2" Roll Pin	1
7	2561212	Cutter Bolt Pin Keeper	1

**COMPLETE BLADE, BOLT AND NUT KIT EX40/EX40HD  
PART #2564497**

# US MOWER FACTORY WARRANTY

**USM WARRANTS ALL OF ITS MOWERS FOR A PERIOD OF 12 MONTHS.**

**THE WARRANTY SPECIFICALLY COVERS MANUFACTURING OR COMPONENT DEFECTS ONLY. DEFECTS OR DAMAGE CAUSED BY NON-US MOWER INSTALLERS OR OWNER/OPERATORS ARE NOT COVERED.**

**NORMAL WEAR PARTS ARE NOT COVERED BY THIS WARRANTY**

## **EXCLUSIONS NOT COVERED BY WARRANTY:**

- COMPONENTS SHOWING EVIDENCE OF OPERATIONAL MISUSE, ABUSE OR MODIFICATION.
- COMPONENTS SHOWING EVIDENCE OF MAINTENANCE NEGLECT INCLUDING, BUT NOT LIMITED TO:
  1. FAILURE TO FOLLOW THE LUBRICATION SCHEDULE
  2. FAILURE TO MAINTAIN PROPER HARDWARE BOLT TORQUE. INSPECT FREQUENTLY.
  3. FAILURE TO MAINTAIN PROPER BEARING PRE-LOAD.
  4. POOR QUALITY OIL, IMPROPER OIL LEVEL
  5. OIL FILTERS NOT REPLACED AS NEEDED, INAPPROPRIATE FILTER INSTALLED
- TECHNICIAN OR MECHANICS TRAVEL TIME
- MACHINE PICK-UP AND OR DELIVERY TO REPAIR FACILITY.
- COMPONENTS CLASSIFIED AS CONSUMABLES.
- HYDRAULIC HOSES NOT OF USM MANUFACTURE-NOTE: IF AN OTHERWISE WARRANTABLE HOSE IS REPLACED FROM OTHER SOURCES, A CREDIT WILL BE ISSUED WHICH WILL REPRESENT USM'S COST OF MANUFACTURING THAT HOSE AND SHIPPING BY UPS GROUND.
- BENT FLAIL SHAFTS OR SHAFT STUBS
- THE WARRANTY WILL BE CONSIDERED VOID IF CLOSED COMPONENTS ARE DISASSEMBLED PRIOR TO RETURN. CLOSED COMPONENTS INCLUDE, BUT ARE NOT LIMITED TO: HYDRAULIC PUMPS, MOTORS, AND CYLINDERS.
- ALL REPLACEMENT COMPONENTS WILL BE SHIPPED TO CUSTOMER/DEALER VIA UPS GROUND. ALL REPLACEMENT COMPONENTS SHIPPED ARE INVOICED AS A MATTER OF COURSE. COMPONENTS THAT REQUIRE EVALUATION AT THE FACTORY MUST BE SHIPPED FREIGHT PREPAID. A CREDIT WILL BE ISSUED FOR THE REPLACEMENT COMPONENT AND FREIGHT WHEN IT IS DETERMINED THAT THE WARRANTY IS APPLICABLE. ALL WARRANTY WORK OR REPLACEMENT COMPONENTS MUST BE PRE-AUTHORIZED BY US MOWER. US MOWER IS NOT RESPONSIBLE FOR UNAUTHORIZED REPAIRS OR REPLACEMENTS. IF THERE ARE QUESTIONS REGARDING THE APPLICABILITY OF WARRANTY, A CALL TO USM IS RECOMMENDED BEFORE WORK PROCEEDS.

## **CREDIT FOR LABOR**

LABOR CREDIT FOR A WARRANTABLE REPAIR WILL BE ISSUED ONLY FOR WORK DONE IN A SERVICE DEALER'S SHOP. NO LABOR CREDIT WILL BE ISSUED FOR WORK DONE IN THE FIELD (I.E., AT THE MACHINE SITE) EXCEPT BY SPECIFIC FACTORY AUTHORIZATION. TRAVEL TIME TO AND FROM MACHINE WILL NOT BE WARRANTED. ACTUAL WARRANTY COMPENSATION WILL BE BASED ON USM FLAT RATE MANUAL.

CREDIT WILL NOT BE ISSUED AND WARRANTY IS NOT VALID FOR ANY UNIT THAT IS NOT PAID WITHIN TERMS OF THE INVOICE INCLUDING THE SERIAL NUMBER FOR PURCHASED COMPONENT REGARDLESS OF THE END USER. WHOLESALER OR DEALER IS RESPONSIBLE FOR ALL COSTS OF WARRANTY REPAIRS UNLESS INVOICE IS WITHIN TERMS.

## **DAMAGE AND INJURY**

USM LIABILITY IS SPECIFICALLY LIMITED TO THE REPLACEMENT OF COMPONENTS FOR ITS PRODUCTS IF A WARRANTABLE DEFECT IS DISCOVERED. COLLATERAL DAMAGE TO PROPERTY OR PERSONAL INJURY IS EXCLUSIVELY THE RESPONSIBILITY OF THE OWNER AND OR OPERATOR SINCE USM HAS NO CONTROL OVER THE CIRCUMSTANCES IN WHICH IT'S EQUIPMENT IS USED. LOST TIME OR EXPENSE WHICH MAY HAVE ACCRUED BECAUSE OF DEFECTS IS NOT COVERED.

## **EXPRESS WARRANTY**

SELLER WARRANTS THAT:

THE GOODS TO BE SUPPLIED PURSUANT TO THIS AGREEMENT (PURCHASERS AGREEMENT TO BUY AND SELLER'S AGREEMENT TO SELL) ARE FIT AND SUFFICIENT FOR THE PURPOSE INTENDED.

THE GOODS ARE MERCHANTABLE, OF GOOD QUALITY AND FREE FROM DEFECTS WITHIN THE SELLER KNOWLEDGE, WHETHER PATENT OR LATENT, IN MATERIAL OR WORKMANSHIP.

THE SELLER HAS TITLE TO THE GOODS SUPPLIED IN THAT THE GOODS ARE FREE AND CLEAR OF ALL LIENS, ENCUMBRANCES AND SECURITY INTERESTS. ALL WARRANTIES MADE IN THIS AGREEMENT, TOGETHER WITH SERVICE WARRANTIES AND GUARANTEES SHALL RUN TO BUYER AND THE ORIGINAL CUSTOMER OF BUYER.

THERE ARE NO OTHER WARRANTIES EITHER EXPRESSED OR IMPLIED

SHOULD YOU HAVE QUESTIONS REGARDING WARRANTY ISSUES OR EXPERIENCE ANY PROBLEMS, PLEASE CALL YOUR DEALER OR US MOWER AT 877.757.7555 OR E-MAIL US @ INFO@USMOWER.COM.

# US MOWER



[WWW.USMOWER.COM](http://WWW.USMOWER.COM)